

## Dispense bank valve, DN 8



## A.u.K. Müller

Solenoid valves  
Control valves  
Special valves and systems

A.u.K. Müller GmbH & Co. KG  
Dresdener Str. 162  
D-40595 Düsseldorf/Germany

Tel.: +49 211 7391-0  
Fax: +49 211 7391-281

e-mail: [info@akmueller.de](mailto:info@akmueller.de)  
Internet: [www.akmueller.de](http://www.akmueller.de)

### series 46.008.x17



### Characteristics

- direct acting
- plunger separated by membrane from medium
- valve bodies can be connected
- PTFE valve seat to inhibit scale build up
- long term performance capability
- flow rate adjustable (flow regulation screw)
- suitable for food and hot water appliances
- works from zero pressure
- similar hydraulic performance for AC or DC types
- other hydraulic connection on request
- complete drainage of valve outlet after shut off
- easy to assemble and service
- coil change without opening of medium circuit
- high operating safety through the use of high quality and 100% final testing of the products

### Applications

- hot / cold drink dispensers
- tank or boiler draining
- automatic animal feeding equipment

### Description

2/2-way solenoid valve of nominal diameter DN 8 for liquid dispense. This valve is direct acting and normally closed (NC).

Valves of this design are medium separated seat valves, where the plunger is separated by a diaphragm from the medium. Valve bodies can directly be connected. The valve seat is made of scale build up inhibiting PTFE.

This valve can be manufactured with a variety of customised connections in DC or AC voltage. Low power or PPM triggering can be used.

Electrical operating safety is achieved by PBT coating of the coil and can be supported by an additional protection circuit.

The valve is available in two body types made of PSU and is distinguished primarily by its food grade and hot water capability.





series 46.008.x17

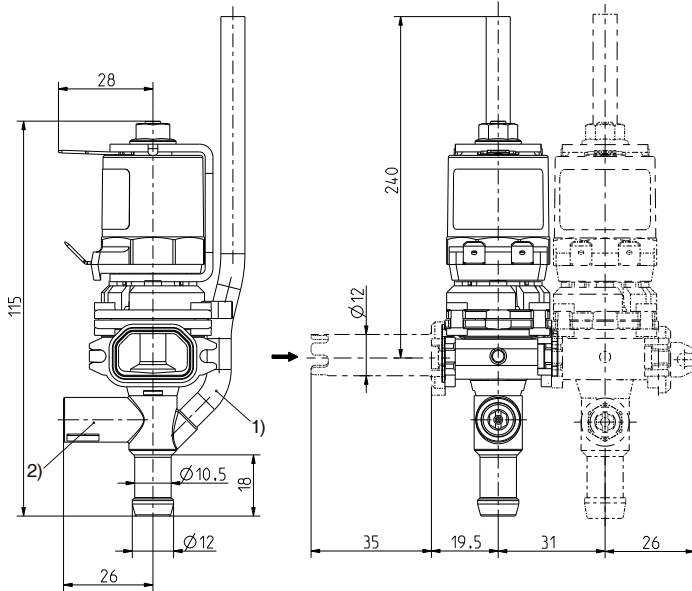

- 1) Ventilation of outlet nozzle to drain downstream tubing completely. Different lengths of breather tube on request.
- 2) Regulation screw for vernier adjustment of flow.

Materials

Valve body	PSU
Valve seat	PTFE
Plunger guide	stainless steel
Plunger	stainless steel
Membrane	VMQ FMQ (on request)
Sealings	VMQ
Coil coating	PBT, PET or epoxy resin

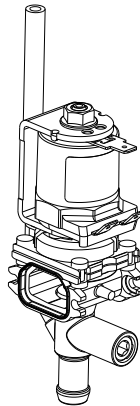

Technical Data

Type	dispense valve		
Construction	2/2-way single chamber valve inlet ninety degree to the outlet, direct acting		
Function	NC (normally closed)		
Fitting position	coil pointing upwards		
Media	cold and heated potable water and physically and chemically similar media		
T-Medium	98	°C.	
T-Ambient	70	°C	
DN	8	mm	
Flow	adjustable at outlet nozzle		
p-Operating	0 - 60	mbar	
Coil type	MS.006		
Nominal voltages	230	V AC	50/60 Hz
	110	V AC	50/60 Hz
	24	V AC	50/60 Hz
	24	V DC	
other voltages on request			
Voltage tolerance	+10% -15%		
Duty cycle	AC 50% (cycle 1 min)		
	DC 100%		
Nominal power	9,5 W	16,4 VA (AC only)	
	Protection type		
Protection type	IP 00	higher IP-classes on request	
	Coil connection		
flat tabs 6,3 x 0,8 mm			others on request
Insulation class	F	according to EN 60730	
	Protection class		
I			according to EN 60730 (for incorporation in class I)

Options

Name		Material
Closure		PSU
Valve body inlet adapter		PSU
Boiler connection		PSU
Inlet elbow nozzle		PSU

Name		Material
Backflow outlet nozzle		PSU
Backflow outlet elbow nozzle		PSU
Fixing Clip		PA 66
Other connections and outlet nozzles on request		





series 46.008.x17

body  
model

~001

~002

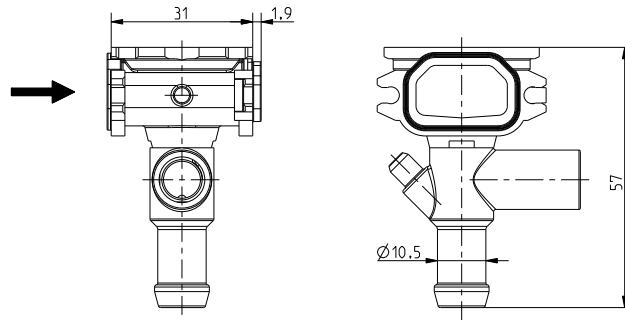

standard

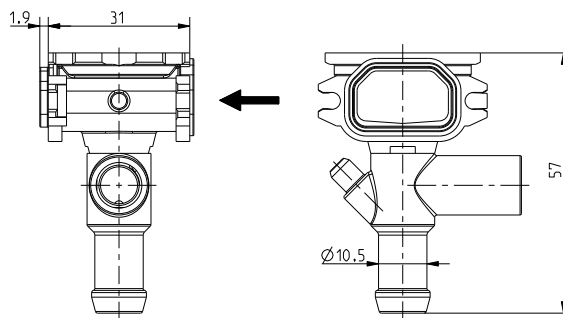



**A.u.K. Müller**