

Product Information

Bi stable integrated cartridge valve, DN 7 urinal applications

Series 050-U07-061 / -091



Description

2/2-way solenoid cartridge servo controlled valve of DN 7 in bi stable version with integrated sensor and electronics, to be used particularly in electronically controlled urinals.

The design's compact outline enables trouble free integration of the unit into the urinals.

A LED flashes each time, to signal that the detection area had been entered or left.

Start up using default settings on power on. Plug on battery is all what is needed.

Within the first 30 minutes after power on, a sleep mode may be activated, to enable an elongated storing period of the battery equipped urinals by reducing bias current.

Individual settings may be achieved by an optional IR-remote control. (detection range, on-off, follow-up time)

The screw in type simplifies assembly, service and check.

Applications

- automatic sanitary urinals



A.u.K. Müller

Solenoid valves
Control valves
Special valves and systems

A.u.K. Müller GmbH & Co. KG
Dresdener Str. 162
D-40595 Düsseldorf/Germany

Tel.: +49(0)211-7391-0
Fax: +49(0)211-7391-281

e-mail: info@akmueller.de
<http://www.akmueller.de>

Characteristics

- servo-controlled
- pre tested functional unit
- long term performance capability
- internal triple pollution protection
- compact design
- optimized Cv-value for DN 7
- optimized water hammer characteristic by low noise emission according to EN 60730
- easy to assemble and service
- standard connection
- cylindrical design
- low power consumption
- any fitting position
- suitable for spray and jet water
- high operating safety through the use of high quality materials and 100% final testing of the products
- optoelectronic IR sensor with micro controller for contactless operating of cartridge valve
- encapsulated electronic, protection type IP 65
- electronic completely wired to cartridge valve
- low bias current for elongated battery lifetime
- enforced flush after 24 hours without any detection
- start up with default settings on power on. Plug on battery is all what is needed

typical performance curve

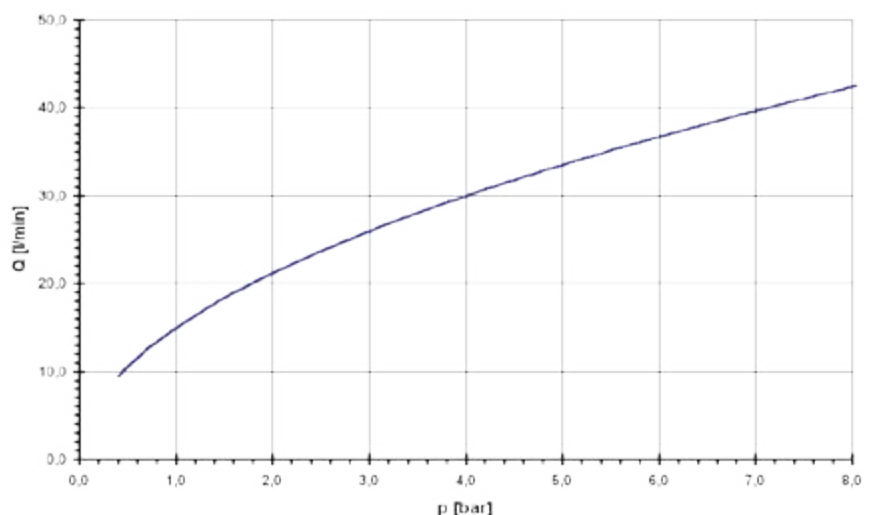



Series 050-U07-061 / -091

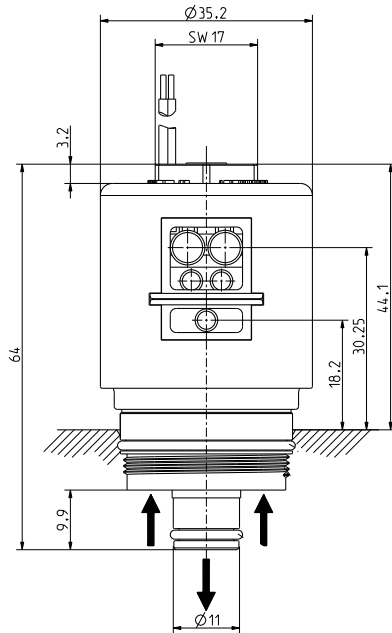

protection windows

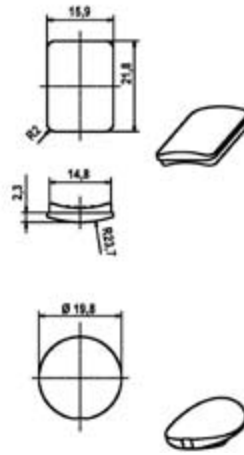

installation within armature using a circular window

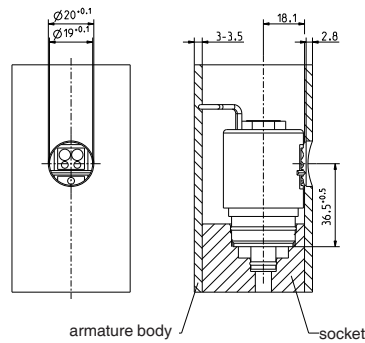

installation within armature using a squared window

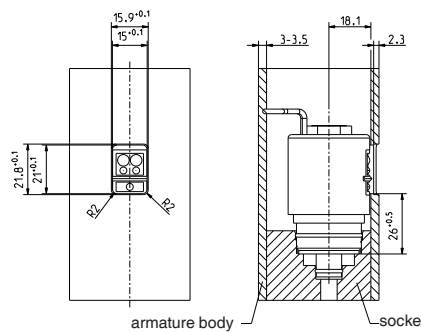

Materials

Valve body	PEI
Plunger guide	stainless steel
Plunger	stainless steel
Membrane and sealings	EPDM NBR (on request) VMQ (on request)
Coil	1.0338 "pot"-bracket
Filter	stainless steel (in inlet)
Top cover	POM

Options

standard cable lenght			IR - remote controll available		
with leads and connector	100	mm	detection range	120 - 800	mm
with leads	120	mm	flush time	0,5 - 15,5	sec
connector	on request		permanent - OFF	enable/ disable	

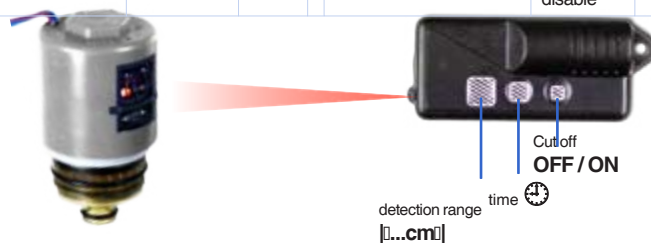

Technical Data

Type	2/2-way-cartridge valve	
Construction	screw in, servo controlled	
Function	bi stabil, pulse controlled	
Connection	thread M28 x 1	
fitting position	any	
Media	cold and heated potable water and physically and chemically similar media	
T-Medium	5 - 70 °C.	
T-Ambient	5 - 60 °C	
DN	7 mm	
p-operating	0,5 - 8,0 bar	
Cv-value	20 l/min (18 max. l/min Silencer)	
Pressure surge	according to EN 60730	
Coil type	MS.033	
Nominal voltage	6 V DC	9 V DC
	special voltages on request	
Operating voltage	5,0 - 6,0 V DC open/close 7,5 - 9,0 V DC open/close	
Signal of low voltage levels	< 5,0 V LED flashing < 4,7 V LED persistent signal, valve will be closed permanent < 7,5 V LED flashing < 7,0 V LED persistent signal, valve will be closed permanent	
Battery voltage detection	automatic	
Grade of noise	II in test housing	
Lifetime of valve	min. 280.000 cycles / 5 a	
Lifetime of battery	6 V Lithium (min. 1.300 mAh) approx. 4 years ... 9 V Alkaline (min. 600 mAh) approx. 2,7 years for 150 actuations / day	
Duty cycle	100%	
Nominal power	0,5 - 1,2 W	
Protection type	IP 65	higher IP classes on request
Insulation class	F	according to EN 60730
Protection class	III	according to EN 60730
IR detection range	automatically on Power ON	
Default settings ..		
Detection range	650	mm (± 25%) w/o IR-window
Min. length of stay	7,5	sek (± 25 sec%)
Flushing time	5,5	sec (± 1 sec)
Enforced flush	every 24	h w/o detection
Follow up time	< 2,5	sec (depends on operating pressure)