

# battery cases *Product Information*



**A.u.K. Müller**

Solenoid valves  
Control valves  
Special valves and systems

A.u.K. Müller GmbH & Co. KG  
Dresdener Str. 162  
D-40595 Düsseldorf/Germany

Tel.: +49(0)211-7391-0  
Fax: +49(0)211-7391-281

e-mail: [info@akmueller.de](mailto:info@akmueller.de)  
<http://www.akmueller.de>

## NBR cases



## Description

Elastomer battery case to slide in a 6V lithium or 9V battery type E with moisture protected battery terminals.

Originally developed as an accessory for the bi stable integral cartridge valves of product line 050-... the elastomer battery cases are singly available with twin flex cable of about 125 mm length and round connector by default.

Additionally, the battery casings are suitable for all appliances requiring an independent power supply.

Due to the moisture protection, they can be utilised in a wide range of similar environments.

The PC battery case enables the protection type IP 65.

## Applications

- sanitary fittings
- photo and video applications
- model making
- use in moistened areas

## Characteristics

- moisture protected battery terminals
- any fitting position
- battery change without tools (not for PC case)

## PC box





**battery type: CR-P2 6V Lithium**

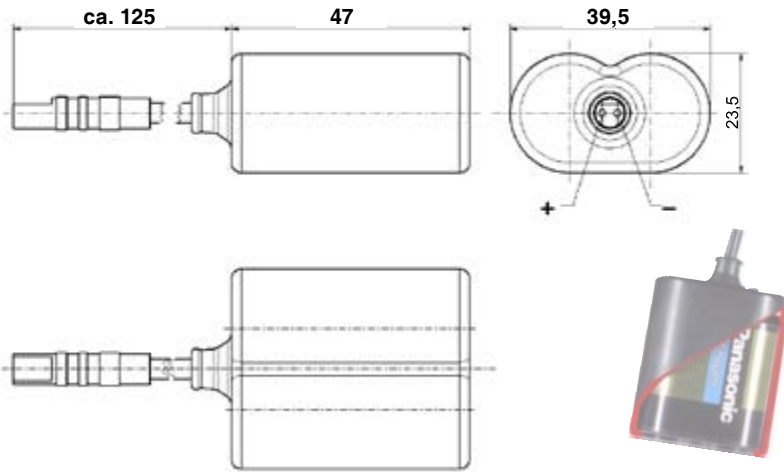

**Technical Data**

<b>Battery types</b>	6V CR-P2 lithium 9V E-block
<b>Construction</b>	elastomer case or plastic housing
<b>Battery terminals</b>	integrated
<b>Cable</b>	Liy 2 x 0,25mm <sup>2</sup>
<b>Cable length</b>	125 mm (by default)
<b>Connection</b>	on request

**battery type: PP3 9V alkaline**

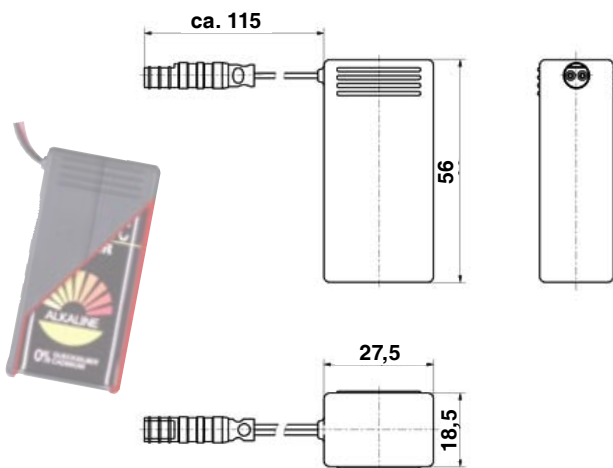

**Materials**

<b>Battery case</b>	NBR
<b>Battery box</b>	PC (polycarbonate)
<b>Cable insulating</b>	PVC

**battery type: PP3 9V alkaline**

