

Product Information

**2/2 way direct acting solenoid valve NC
DN 1 - 5 not media separated, duty cycle 50 %**



A.u.K. Müller

Solenoid valves
Control valves
Special valves and systems

A.u.K. Müller GmbH & Co. KG
Dresdener Str. 162
D-40595 Düsseldorf/Germany

Tel.: +49 211 7391-0
Fax: +49 211 7391-281

e-mail: info@akmueller.de
Internet: www.akmueller.de

series 43.00x.142



Characteristics

- direct acting
- compact design
- long term performance capability
- suitable for food and hot water appliances
- works from zero pressure
- similar hydraulic performance for AC or DC types
- DC version with low noise and low wear out due to internal plunger attenuation
- easy to assemble and service
- coil change without opening of medium circuit, coil can be mounted 4 x 90°
- high operating safety through the use of high quality and 100% final testing of the product

Applications

- hot / cold drink dispensers
- medical equipment
- automatic welding equipment

Description

2/2-way solenoid valve of different nominal diameters for use with neutral gases and liquids. This valve is direct controlled and normally closed (NC).

Valves of this design are single chamber straight through valves, with nozzles at outlet and inlet.

The valve body is made of PEI, which is suitable for hot water applications.

This valve is designed for intermittent operation (duty cycle 50%).

Electrical operating safety is achieved by using high quality materials of insulation class F and can be supported by an additional protection circuit.

typical performance curve (fluids)

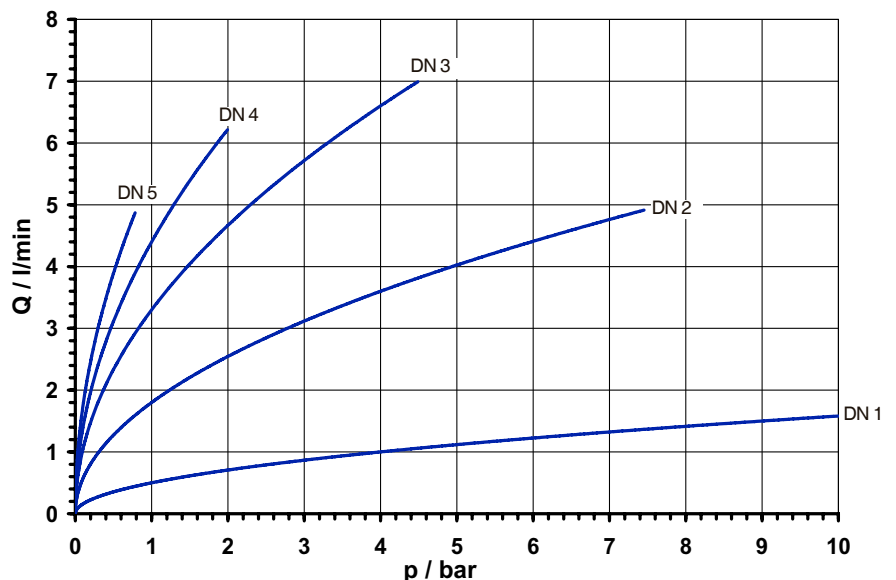

2/2 way direct acting solenoid valve NC
DN 1 - 5 not media separated, duty cycle 50 %



A.u.K. Müller

series 43.00x.142

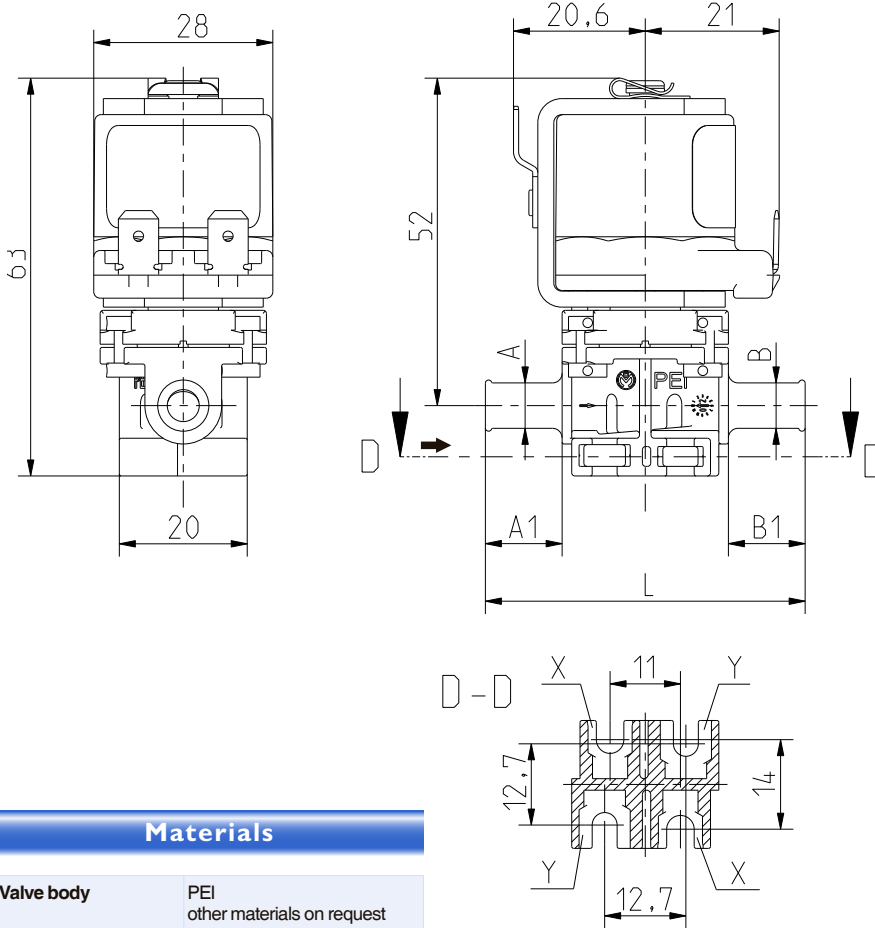

slot for nut
 X = M4 DIN EN ISO 4032
 Y = N 6-32 UNC ANSI B1.1

Materials

| | |
|----------------------|-----------------------------------|
| Valve body | PEI other materials on request |
| Plunger guide | stainless steel |
| Plunger | stainless steel |
| Membrane | EPDM FPM (on request) |
| Coil coating | PBT, PET or epoxy resin |

Technical Data

| | | |
|---|--|--------------------|
| Type | solenoid valve | |
| Construction | 2/2-way single chamber straight valve, direct acting | |
| Function | NC (normally closed) | |
| Fitting position | any | |
| Media | neutral gases, cold and heated potable water and physically and chemically similar media | |
| T-Medium for connections nozzle | 98 | °C max. |
| John Guest | 65 | °C max. on request |
| T-Ambient for connections nozzle | 70 | °C max. |
| John Guest | 65 | °C max. on request |

| DN | Cv-value | p-Operating | |
|----|----------|-------------------|------------------------|
| | | in flow direction | against flow direction |
| mm | l/min | bar | bar |
| 1 | 0,5 | 0 - 10,0 | 0 - 10,0 |
| 2 | 1,8 | 0 - 7,5 | 0 - 6,0 |
| 3 | 3,3 | 0 - 4,5 | 0 - 3,0 |
| 4 | 4,4 | 0 - 2,0 | 0 - 1,5 |
| 5 | 5,5 | 0 - 0,8 | 0 - 0,8 |

| | | |
|--------------------------|---------------------------|---|
| Coil type | MS.026 | |
| Nominal voltages | 12 | V DC |
| | 24 | V DC |
| | 24 | V AC |
| | 110 | V AC |
| | 230 | V AC |
| | 50/60 Hz | |
| | 50/60 Hz | |
| | other voltages on request | |
| Voltage tolerance | +10% -15% | |
| Duty cycle | 50% | |
| Nominal power | 10 W | 15 VA (AC) |
| Protection Type | IP 00 | |
| Coil connections | flat tabs 6,3 x 0,8 mm | |
| Insulation class | F | according to EN 60730 |
| Protection class | I | according to EN 60730 (for incorporation in class I) |

Options

| | Inlet | | Outlet | | |
|--------|-------|----|--------|----|----|
| | Ø | A1 | Ø | B1 | L |
| nozzle | 7 | 12 | 7 | 12 | 50 |

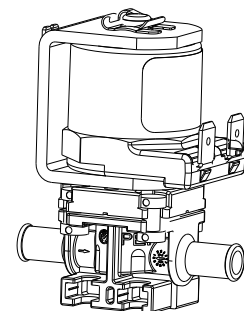



series 43.00x.142

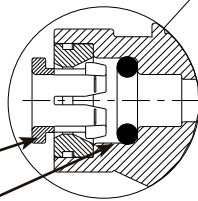
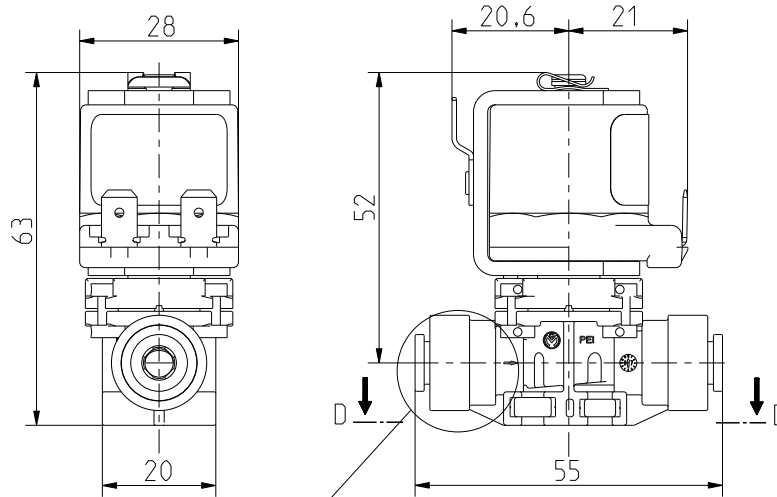

| | |
|-----------------------------|--------------------------|
| John Guest cartridge | POM |
| o-ring | EPDM NBR (on request) |

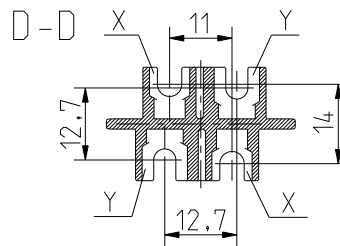

slot for nut
 X = M4 DIN EN ISO 4032
 Y = N 6-32 UNC ANSI B1.1

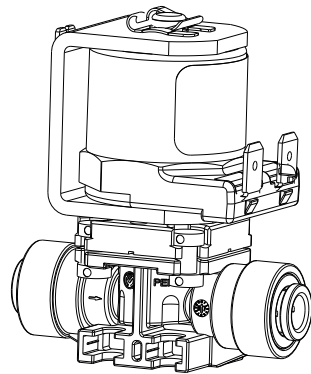

The applicability of the John Guest connection to medium- or ambient temperatures higher than 65°C is temporarily feasible, but has to be verified accordingly in the respective application.

Options

| | Inlet | Outlet | Length | |
|----------------------|-------|--------|--------|------------|
| | Ø | Ø | | |
| John Guest cartridge | 6 | 6 | 55 | on request |
| John Guest cartridge | 8 | 8 | 55 | on request |
| John Guest cartridge | 1/4" | 1/4" | 55 | on request |
| John Guest cartridge | 5/16" | 5/16" | 55 | on request |



A.u.K. Müller