

Product Information

Float Valve, DN 10



A.u.K. Müller

Solenoid valves
Control valves
Special valves and systems

A.u.K. Müller GmbH & Co. KG
Dresdener Str. 162
D-40595 Düsseldorf/Germany

Tel.: +49 211 7391-0
Fax: +49 211 7391-281

e-mail: info@akmueller.de
Internet: www.akmueller.de

Series 21.010.110



Characteristics

- servo-controlled
- redirection of flow by 90°
- operation largely independent from inlet pressure
- easy to assemble and service
- compact design
- suitable for heated water up to 60 °C
- adjustable level height
- high operating safety through the use of high quality materials and 100% final testing of the products

Applications

- tank filling
- irrigation systems
- high pressure cleaning devices (system separation according to EN 1717)
- ice machines
- industrial appliances

Description

Servo-controlled valve nominal diameter DN 10, which closes by means of buoyancy of a floater to control level in tanks.

If liquid is drained from the tank, the float valve refills automatically and closes when the maximum level has been reached.

The outlet jet is directed on to a guide, which pushes the lever to closed. This effects a relative constant flow, covering a wide pressure range. An overflow of small tanks will be prevented during the initial filling.

By reaching a sufficient level within the tank during refill, the final closing procedure is due to the buoyancy of the float body.

Valves of this design are single chamber valves with the inlet ninety degrees to the outlet. The valve, having a glass fibre reinforced polyamid housing, can be manufactured with various connections and is suitable up to 60° by using a PE-floater.

typical performance curve

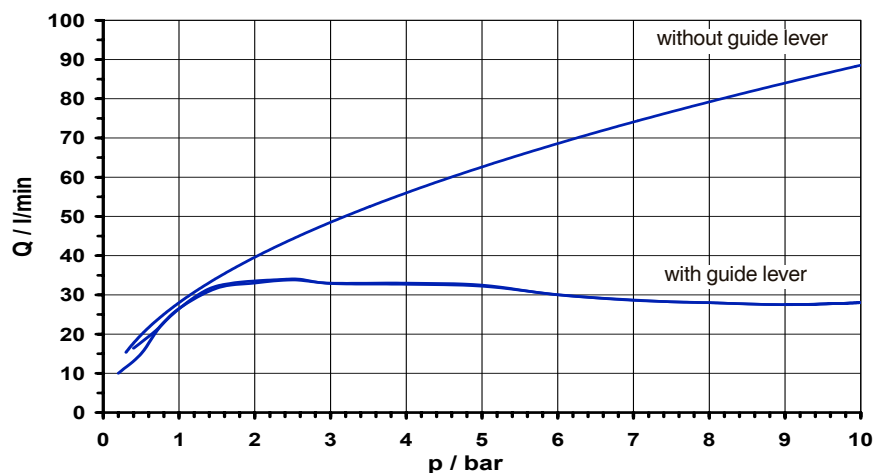



Series 21.010.110

Technical Data

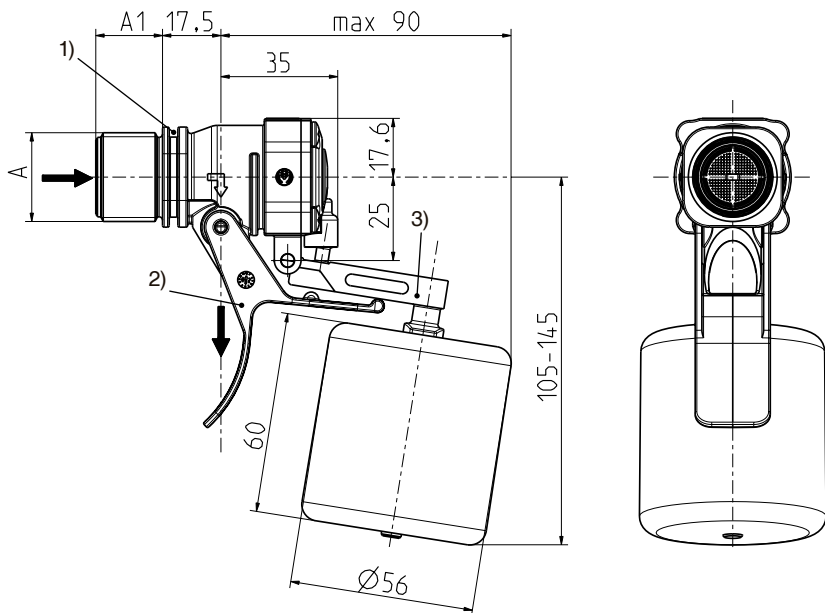

Type	float valve	
Construction	2/2-way single chamber valve inlet ninety degree to outlet, servo-controlled	
Function	closed by buoyancy of float	
Fitting position	float vertically downwards	
Media	cold and heated potable water and physically and chemically similar media	
T-Medium	30	°C max. polystyrene
	60	°C max. PE
T-Ambient	see T-Medium	
DN	10	mm
p-Operating	0,3 - 10,0 bar	
Cv-value	28	l/min
Flow direction	marked by arrow	
Float body	position adjustable	
filter	fitted in inlet	

Versions on request

Materials

Valve housing	PA 66 glass fibre reinforced
Membrane and sealings	EPDM
Float cylinder	PE-foam polystyrene on request
Float lever	POM
Guide lever	POM
Filter	POM stainless steel on request

	Guide lever	Flow regulator in inlet	
			<p>The individual flow rate has to be synchronised with the water surface area within tank at float level height</p>
a)	<input type="radio"/>	<input type="radio"/>	No flow restriction. A restriction of the pressure range (e.g. 0,5 - 8 bar) may be recommended, if the rise of the water level within the tank may lead to an overflow by a gush of water.
b)	<input checked="" type="radio"/>	<input type="radio"/>	Flow restriction above 1,5 bar to approx. 35 l/min.
c)	<input type="radio"/>	<input checked="" type="radio"/>	Flow restriction above 1 bar. Depends on the used flow regulator with reduced tolerance compared to b) For small tanks a) flow restriction ≤ 20 l/min is recommended.

- 1) Fixing groove
- 2) Guide lever
- 3) Float lever

● installed ○ not installed

Options

Material	Inlet	Outlet	
	Ø A	A1	Ø
PA 66	G 1/2	15,0	10,0
PA 66	G 3/4	20,0	10,0
PA 66	G 3/4	30,0	10,0
PA 66	.75x11.5 NH	20,0	10,0 on request
PA 66	G 3/4 female	30,0	10,0
PA 66	.75x11.5 NH female	30,0	10,0

