

# Product Information

## Pressure Reducer



## A.u.K. Müller

Solenoid valves  
Control valves  
Special valves and systems

A.u.K. Müller GmbH & Co. KG  
Dresdener Str. 162  
D-40595 Düsseldorf/Germany

Tel.: +49 211 7391-0  
Fax: +49 211 7391-281

e-mail: [info@akmueller.de](mailto:info@akmueller.de)  
Internet: [www.akmueller.de](http://www.akmueller.de)

### Series 42.010.000



### Characteristics

- outlet pressure adjustable
- balancing of inlet pressure
- suitable for hot water up to 90°C
- ambient temperature up to 70°C
- reduced noise of flow
- compact design
- long term performance capability by the use of high quality materials

### Applications

- pressure reducing
- flow rate regulation
- protection of pressure caused damages of pipework downstream

### Description

The pressure regulator converts variable inlet pressure into a lower, constant outlet pressure. It can be used to protect equipment from high or inconsistent incoming medium pressure.

This reduced and constant outlet pressure also enables a constant flow rate to be achieved independently of the incoming pressure. The orifice used to maintain this constant flow rate should be placed immediately after the pressure reducer. The pressure can easily be adjusted within the regulators specification range and is ideal for applications that require a constant flow rate or a specific timed volume delivery.

To ensure operation and long reliability of the pressure regulator it is recommended that a dirt strainer is fitted to the inlet. Check valves or solenoid valves can be placed downstream of the regulator.



**Series 42.010.000**

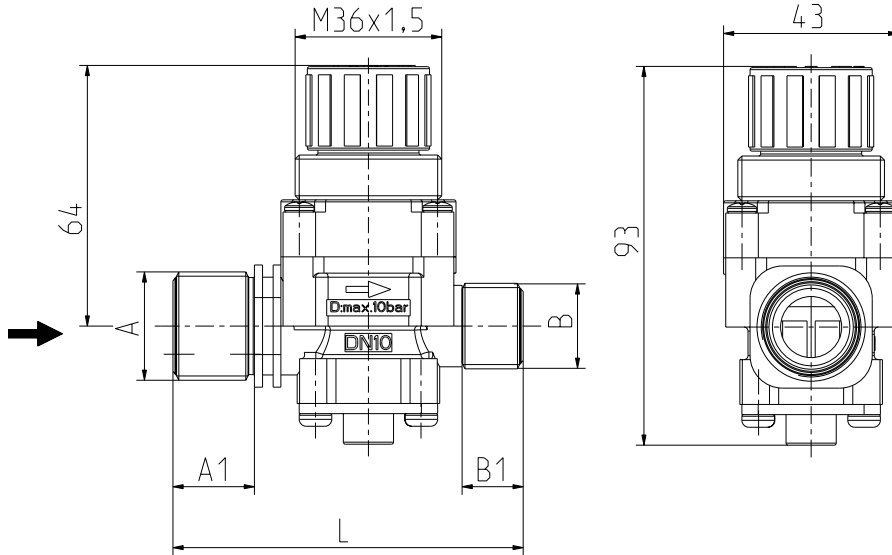

**Technical Data**

<b>Type</b>	pressure reducer	
<b>Construction</b>	single chamber straight	
<b>Fitting position</b>	any, direction of flow marked by arrow	
<b>Media</b>	cold and heated potable water and physically and chemically similar media	
<b>T-Medium</b>	90	°C max.
<b>T-Ambient</b>	70	°C max.
<b>DN</b>	10	mm
<b>p-Operating</b>	3 - 10	bar (min. 2 bar above outlet pressure)
<b>p-Outlet</b>	1 - 8	bar
<b>Cv-value</b>	25	l/min
<b>Attachment</b>	Using flange or center nut M 36 x 1,5	

**Materials**

<b>Valve body</b>	PA 66 glass fibre reinforced
<b>Spring and other metal parts</b>	stainless steel
<b>Membrane and sealings</b>	EPDM

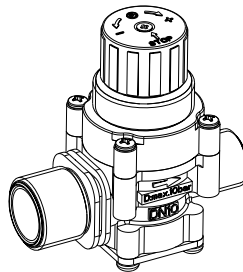

**Options**

Material	Inlet		Outlet		Length	
	Ø A	A1	Ø B	B1	L	
PA 66	G 3/4	20	G 1/2	15	86	
PA 66	G 3/8	13	G 3/8	13	77	
PA 66	G 3/4	20	G 3/4 female gland nut	20	88	
PA 66	G 3/4	20	G 1/2	15	106	pressure gauge connection G 1/4
PA 66	G 1/2	15	G 1/2	15	101	pressure gauge connection G 1/4
PA 66	G 3/4	20	G 1/2	15	106	pressure gauge connection M10 x 1
PA 66	G 3/4	20	G 3/4 female gland nut	42	107,5	pressure gauge connection G 1/4
PA 66	G 3/4	20	G 3/4	18	109	pressure gauge connection G 1/4