

# Impeller Pump 420 mbar

# Product Information



## A. u. K. Müller

Solenoid valves  
Control valves  
Special valves and systems

A. u. K. Müller GmbH & Co. KG  
Dresdener Str. 162  
D-40595 Düsseldorf/Germany

Tel.: +49(0)211-7391-0  
Fax: +49(0)211-7391-281

e-mail: info@akmueller.de  
Internet: www.akmueller.de

### Series 41.008.400



### Characteristics

- Low running noise
- Vibration dampers at the attachment points
- Brushless motor
- Hermetic separation of hydraulic and drive unit
- Suitable for food and hot water applications
- Not self-priming
- Long life cycle (> 1500 hours under laboratory conditions)
- Compact design
- Easy disassembly for cleaning due to bayonet lock

### Description

The 41.008.400 series pump is designed to increase pressure and improve dosing consistency.

It is ideally suited for applications where a low water level in a boiler causes insufficient flow through conventional outlet valves.

The use of the pump allows a largely independent placement of outlet valves above the water level of the boiler.

The special design of the hydraulic part of the pump enables low-cavitation operation. High media temperatures of up to 96 °C are therefore possible without significant loss of pump performance.

To increase the maintenance intervals, a low-wear, brushless motor is used in this pump.

By using the bayonet lock, the pump can be easily dismantled and cleaned.

The pump housing is suitable for hot water and has a long life cycle of more than 1500 hours (tested under laboratory conditions) due to the high end materials and design solutions used.

This is achieved by hermetically separating the drive unit from the hydraulic unit. Leakage, as is common on the seals otherwise used on rotating drive shafts, is thus prevented.

The pump is equipped with vibration dampers that further minimise the already very low noise emissions when installed.

### Applications

- Hot / cold drink dispensers
- Pressure increase at low boiler level
- Tank draining
- Industrial appliances
- Bottling plants
- Cleaning Systems
- Water dispenser
- Air humidifier

### Approvals

Approved versions available on request:



KTW - BWGL



- EG 1935/2004
- KTW - BWGL
- NSF 169
- WRAS
- Others on request

Typical Performance Curve  
(measured under laboratory conditions)

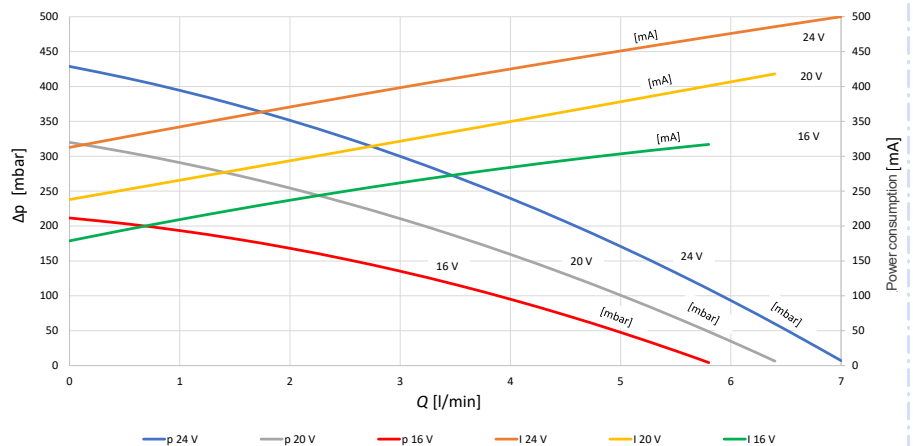



### Series 41.008.400

### Technical Data

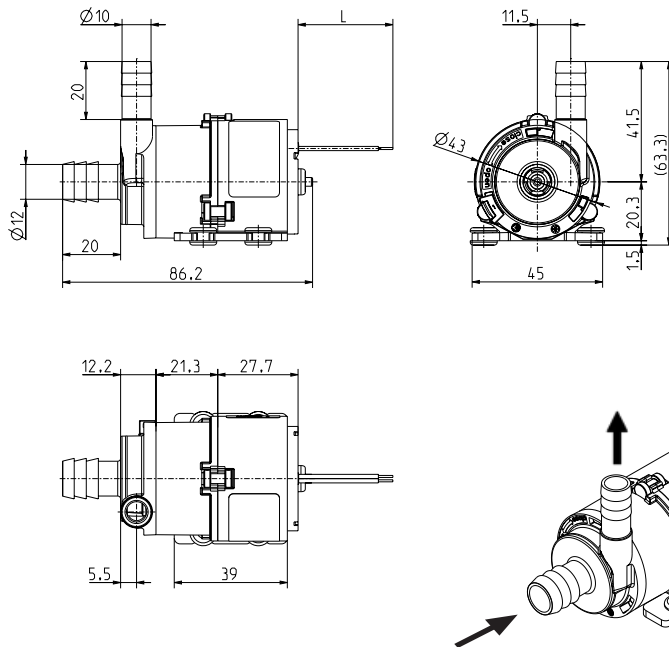

<b>Type</b>	pump	
<b>Construction</b>	impeller pump	
<b>Function</b>	pressure increase	
<b>Mounting position</b>	preferably motor horizontal or motor points downwards	
<b>Media</b>	cold and heated potable water and physically and chemically similar media	
<b>T-Medium</b>	5 - 96	°C
<b>T-Ambient</b>	5 - 60	°C
<b>DN</b>	8	mm
<b>p-max</b>	420	mbar
<b>Max. volume flow</b>	7,0	l/min
<b>Nominal voltages</b>	24	V DC
	PWM on request	
<b>Voltage tolerance</b>	max. permitted Voltage 26 V DC	
<b>Nominal power</b>	max, 10 W	
<b>Protection Type</b>	IP 00	
<b>Motor connections</b>	strand (Polarity: red + / black -)	
<b>Cabel</b>	AWG 28	
<b>Cabel length</b>	300 ± 30 mm	

### Materials

<b>Pump body</b> (not in contact with media)	PBT
<b>Pump body</b> (in contact with media)	PPSU
<b>Shaft</b>	stainless steel
<b>Sealings</b>	EPDM

#### Attention!

Pump bodies made of PPSU must not come into contact with:

Acetone, ether, ketones, aromatic hydrocarbons, chlorinated hydrocarbons, oxidising acids and anaerobic adhesives.

#### Attention!

Functional impairments and/or damage to the pump and / or damage to the pump may occur during

- Operation with inverted polar suction.
- Operation under strong vibrations.
- Operation after the pump has been subjected to strong vibrations, e.g. by falling down.
- Operation without medium (dry running).
- Operation with media containing particles with magnetic properties.

**A corresponding mounting plate is provided by the operator.**

Example mounting plate

